

Link Replicator for Fibre Channel, Gigabit Ethernet, and HDTV Data Rates

FEATURES

- Replicates Serial Links Such as Fibre Channel, Gigabit Ethernet, and HDTV Links
- T11 Fibre Channel Compliant at 1.0634 Gb/s
- IEEE802.3-2005 Gigabit Ethernet Compliant at 1.25 Gb/s (1000Base-X)
- Support for SMPTE-292M Data Rate at 1.485 Gb/s
- Compatible With VSC7132-01
- No External Components Required
- 0.455 W Maximum Power Dissipation
- 3.3 V Power Supply

- 28-Pin, 4,4 mm × 9,7 mm TSSOP Package
- Footprint Compatible with VSC7132

APPLICATIONS

- Test Equipment
- Gigabit Ethernet and Fibre Channel Switches/Repeaters

DESCRIPTION

The SN65LVCP15 is a high performance serial link mux for use in Fibre Channel (1.0625 Gb/s), Gigabit Ethernet (1.25 Gb/s), and other high speed interface applications. A common application involves a serializer/deserializer (SerDes), such as the TLK2201B, which would normally be connected to the IN± and OUT± ports in order to provide duplicate set of links on the IN0/OUT0 and IN1/OUT1 ports. This type of application is often used to implement high speed test ports that can be monitored without affecting the serial data stream of the application. A popular application is in Line Cards, that use serial links from a SerDes like TLK2201B ([SLLS585](#)), where the SN65LVCP15 provides redundant, hot-swappable links to redundant Switch Fabric Cards.

During normal operation, IN is sent to both OUT0 and OUT1 whose buffers are enabled when OE0 and OE1 are HIGH. OUT0 can select between IN and IN1. OUT1 can select between IN and IN0. OUT can select between IN0 and IN1.

In Link Replicator applications, such as the Line Card to Switch Card links, IN is transmitted to both OUT0 and OUT1 which either IN0 or IN1 is selected at OUT. In host Adapter applications, IN goes to OUT0 (an internal connector) which returns data and IN0. IN0 is looped to OUT1 (an external connector) which returns data on IN1 and then back to the SerDes on OUT.



Please be aware that an important notice concerning availability, standard warranty, and use in critical applications of Texas Instruments semiconductor products and disclaimers thereto appears at the end of this data sheet.



These devices have limited built-in ESD protection. The leads should be shorted together or the device placed in conductive foam during storage or handling to prevent electrostatic damage to the MOS gates.

ORDERING INFORMATION

ORDERABLE PART NUMBER	DESCRIPTION
SN65LVCP15PW ⁽¹⁾	28-Pin TSSOP, 4,4 mm x 9,7 mm Body

(1) For the most current package and ordering information, see the Package Option Addendum at the end of this document, or see the TI website at www.ti.com.

ABSOLUTE MAXIMUM RATINGS⁽¹⁾

	VALUE	UNIT
V _{DD} Power supply voltage, TTL	0.5 to 4.0	V
V _{IN(P)} DC input voltage, PECL	-0.5 to V _{DD} +0.5	V
V _{IN(T)} DC input voltage, TTL	-0.5 to +5.5	V
V _{IN(TTL)} DC voltage applied to outputs for high output state	-0.5 to V _{DD} +0.5	V
ESD Electrostatic discharge voltage (human body model)	2	kV
T _{JA} Junction to Ambient Thermal Resistance (Assumes High K Board)	61.7	°C/W

(1) Stresses listed under absolute maximum ratings may be applied to devices one at a time without causing permanent damage. Functionality at or above the values listed is not implied. Exposure to these values for extended periods may affect device reliability.

RECOMMENDED OPERATING CONDITIONS

	MIN	MAX	UNIT
V _{DD} Power supply voltage	3.14	3.47	V
T _C Case operating temperature	0	85	°C

AC ELECTRICAL CHARACTERISTICS

over recommended operating conditions (unless otherwise noted)

PARAMETER	TEST CONDITIONS	MIN	TYP	MAX	UNIT
f Operating frequency range		1		1.5	Gb/s
t ₁ Flow-through propagation delay	Delay from any input to any output			1	ns
t _r , t _f Serial data rise and fall time	20% to 80%			300	ps
t _{DJ} Deterministic jitter added to serial input	1 Gb/s to 1.25 Gb/s. Measured on K28.5+, K28.5- pattern			35	ps pp
	1.25 Gb/s to 1.5 Gb/s. Measured on K28.5+, K28.5- pattern			45	

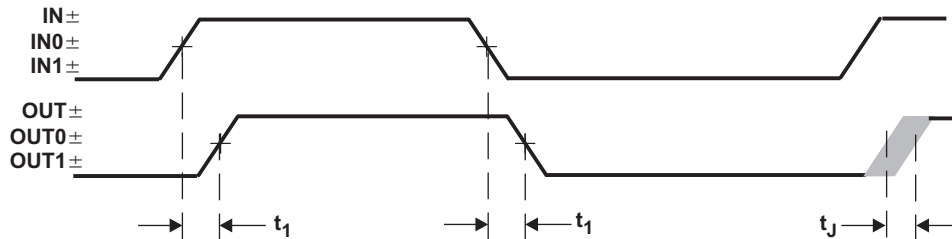

Figure 1. Timing Waveforms

DC ELECTRICAL CHARACTERISTICS

over recommended operating conditions (unless otherwise noted)

PARAMETER		TEST CONDITIONS	MIN	TYP	MAX	UNIT
$V_{IH(TTL)}$	Input HIGH voltage		2	5.5		V
$V_{IL(TTL)}$	Input LOWS voltage		0	0.8		V
$I_{IH(TTL)}$	Input HIGH current	$V_{IN} = 2.4\text{ V}$	-100		100	μA
$I_{IL(TTL)}$	Input HIGH current	$V_{IN} = 0.5\text{ V}$	-100		100	μA
V_{DD}	Supply voltage	$V_{DD} = 3.30\text{ V} \pm 5\%$	3.14		3.47	V
I_{DD}	Supply current	Outputs open, $V_{DD} = V_{DD\text{ max}}$			131	mA
P_D	Power dissipation	Outputs open, $V_{DD} = V_{DD\text{ max}}$			455	mW
ΔV_{IN}	Receiver differential peak-to-peak input sensitivity (IN, IN0, IN1)	AC coupled, Internally biased at $V_{DD}/2$	300		2600	mV _{PP}
ΔV_{OUT50}	Output differential peak-to-peak voltage swing (OUT, OUT0, OUT1)	50 Ω to $V_{DD} - 2\text{ V}$	1000		2200	mV _{PP}
ΔV_{OUT75}		75 Ω to $V_{DD} - 2\text{ V}$	1200		2200	mV _{PP}

APPLICATION EXAMPLE

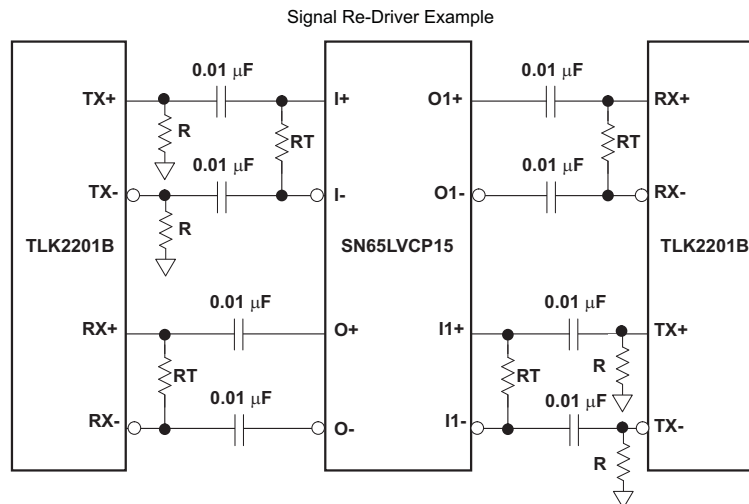

R is 150 Ω for both 100 Ω differential or 150 Ω differential traces.

RT matches the differential impedance of the link.

For optimal signal integrity performance, A/C coupling is recommended.

Figure 2. TLK2201B and SN65LVCP15 Interconnect

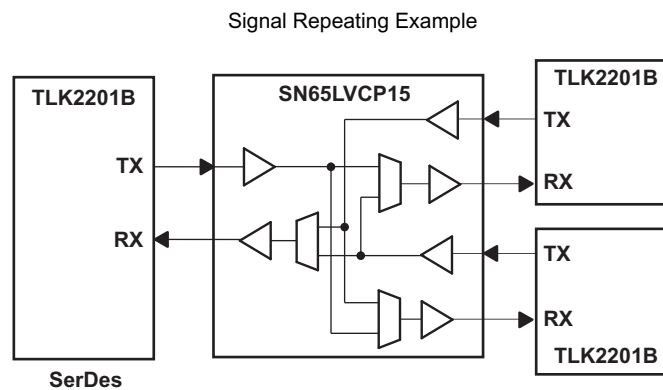
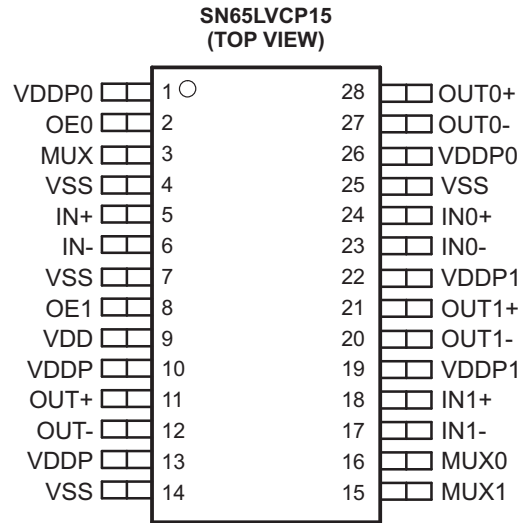

Figure 3.

PACKAGE INFORMATION – PIN DIAGRAM



PIN FUNCTIONS

PIN		TYPE	LEVEL	DESCRIPTION
NO.	NAME			
5, 6 24, 23 18, 17	IN+, IN- IN0+, IN0- IN1+, IN1-	I	PECL	Differential (biased to $V_{DD}/2$) High-speed serial inputs
11, 12 28, 27 21, 20	OUT+, OUT- OUT0+, OUT0- OUT1+, OUT1-	O	PECL	Differential high-speed serial outputs
2 8	OE0 OE1	I	TTL	OE0/OE1 enables OUT0/OUT1 when HIGH. When LOW, OUTx is powered down and both OUTx+ and OUTx- float HIGH.
3	MUX	I	TTL	Determines source of OUT. Selects either IN0 (LOW) or IN1 (HIGH).
15	MUX1	I	TTL	Determines source of OUT1. Selects either IN (HIGH) or IN0 (LOW).
16	MUX0	I	TTL	Determines source of OUT0. Selects either IN (LOW) or IN1 (HIGH).
9	VDD	Pwr		3.3 V power supply for digital logic
10, 13 1, 26 19, 22	VDDP VDDP0 VDDP1	Pwr		High-speed output power supply: 3.3 V supply for PECL drivers. VDDP0 is for OUT0, VDDP is for OUT, and VDDP1 is for OUT1.
4, 7 14, 25	VSS	Pwr		Ground

MOISTURE SENSITIVITY LEVEL

This device is rated moisture sensitivity level 3 or better as specified in the joint IPC and JEDEC standard IPC/JEDEC J-STD-020. For more information, see the IPC and JEDEC standards.

PACKAGING INFORMATION

Orderable Device	Status ⁽¹⁾	Package Type	Package Drawing	Pins	Package Qty	Eco Plan ⁽²⁾	Lead/Ball Finish	MSL Peak Temp ⁽³⁾
SN65LVCP15PW	ACTIVE	TSSOP	PW	28	50	Green (RoHS & no Sb/Br)	CU NIPDAU	Level-1-260C-UNLIM
SN65LVCP15PWR	ACTIVE	TSSOP	PW	28	2000	Green (RoHS & no Sb/Br)	CU NIPDAU	Level-1-260C-UNLIM

⁽¹⁾ The marketing status values are defined as follows:

ACTIVE: Product device recommended for new designs.

LIFEBUY: TI has announced that the device will be discontinued, and a lifetime-buy period is in effect.

NRND: Not recommended for new designs. Device is in production to support existing customers, but TI does not recommend using this part in a new design.

PREVIEW: Device has been announced but is not in production. Samples may or may not be available.

OBsolete: TI has discontinued the production of the device.

⁽²⁾ Eco Plan - The planned eco-friendly classification: Pb-Free (RoHS), Pb-Free (RoHS Exempt), or Green (RoHS & no Sb/Br) - please check <http://www.ti.com/productcontent> for the latest availability information and additional product content details.

TBD: The Pb-Free/Green conversion plan has not been defined.

Pb-Free (RoHS): TI's terms "Lead-Free" or "Pb-Free" mean semiconductor products that are compatible with the current RoHS requirements for all 6 substances, including the requirement that lead not exceed 0.1% by weight in homogeneous materials. Where designed to be soldered at high temperatures, TI Pb-Free products are suitable for use in specified lead-free processes.

Pb-Free (RoHS Exempt): This component has a RoHS exemption for either 1) lead-based flip-chip solder bumps used between the die and package, or 2) lead-based die adhesive used between the die and leadframe. The component is otherwise considered Pb-Free (RoHS compatible) as defined above.

Green (RoHS & no Sb/Br): TI defines "Green" to mean Pb-Free (RoHS compatible), and free of Bromine (Br) and Antimony (Sb) based flame retardants (Br or Sb do not exceed 0.1% by weight in homogeneous material)

⁽³⁾ MSL, Peak Temp. -- The Moisture Sensitivity Level rating according to the JEDEC industry standard classifications, and peak solder temperature.

Important Information and Disclaimer:The information provided on this page represents TI's knowledge and belief as of the date that it is provided. TI bases its knowledge and belief on information provided by third parties, and makes no representation or warranty as to the accuracy of such information. Efforts are underway to better integrate information from third parties. TI has taken and continues to take reasonable steps to provide representative and accurate information but may not have conducted destructive testing or chemical analysis on incoming materials and chemicals. TI and TI suppliers consider certain information to be proprietary, and thus CAS numbers and other limited information may not be available for release.

In no event shall TI's liability arising out of such information exceed the total purchase price of the TI part(s) at issue in this document sold by TI to Customer on an annual basis.

TAPE AND REEL INFORMATION



QUADRANT ASSIGNMENTS FOR PIN 1 ORIENTATION IN TAPE



*All dimensions are nominal

Device	Package Type	Package Drawing	Pins	SPQ	Reel Diameter (mm)	Reel Width W1 (mm)	A0 (mm)	B0 (mm)	K0 (mm)	P1 (mm)	W (mm)	Pin1 Quadrant
SN65LVCP15PWR	TSSOP	PW	28	2000	330.0	16.4	7.1	10.4	1.6	12.0	16.0	Q1

TAPE AND REEL BOX DIMENSIONS



*All dimensions are nominal

Device	Package Type	Package Drawing	Pins	SPQ	Length (mm)	Width (mm)	Height (mm)
SN65LVCP15PWR	TSSOP	PW	28	2000	346.0	346.0	33.0

PW (R-PDSO-G**)

PLASTIC SMALL-OUTLINE PACKAGE

14 PINS SHOWN



4040064/F 01/97

- NOTES: A. All linear dimensions are in millimeters.
 B. This drawing is subject to change without notice.
 C. Body dimensions do not include mold flash or protrusion not to exceed 0,15.
 D. Falls within JEDEC MO-153

IMPORTANT NOTICE

Texas Instruments Incorporated and its subsidiaries (TI) reserve the right to make corrections, modifications, enhancements, improvements, and other changes to its products and services at any time and to discontinue any product or service without notice. Customers should obtain the latest relevant information before placing orders and should verify that such information is current and complete. All products are sold subject to TI's terms and conditions of sale supplied at the time of order acknowledgment.

TI warrants performance of its hardware products to the specifications applicable at the time of sale in accordance with TI's standard warranty. Testing and other quality control techniques are used to the extent TI deems necessary to support this warranty. Except where mandated by government requirements, testing of all parameters of each product is not necessarily performed.

TI assumes no liability for applications assistance or customer product design. Customers are responsible for their products and applications using TI components. To minimize the risks associated with customer products and applications, customers should provide adequate design and operating safeguards.

TI does not warrant or represent that any license, either express or implied, is granted under any TI patent right, copyright, mask work right, or other TI intellectual property right relating to any combination, machine, or process in which TI products or services are used. Information published by TI regarding third-party products or services does not constitute a license from TI to use such products or services or a warranty or endorsement thereof. Use of such information may require a license from a third party under the patents or other intellectual property of the third party, or a license from TI under the patents or other intellectual property of TI.

Reproduction of TI information in TI data books or data sheets is permissible only if reproduction is without alteration and is accompanied by all associated warranties, conditions, limitations, and notices. Reproduction of this information with alteration is an unfair and deceptive business practice. TI is not responsible or liable for such altered documentation. Information of third parties may be subject to additional restrictions.

Resale of TI products or services with statements different from or beyond the parameters stated by TI for that product or service voids all express and any implied warranties for the associated TI product or service and is an unfair and deceptive business practice. TI is not responsible or liable for any such statements.

TI products are not authorized for use in safety-critical applications (such as life support) where a failure of the TI product would reasonably be expected to cause severe personal injury or death, unless officers of the parties have executed an agreement specifically governing such use. Buyers represent that they have all necessary expertise in the safety and regulatory ramifications of their applications, and acknowledge and agree that they are solely responsible for all legal, regulatory and safety-related requirements concerning their products and any use of TI products in such safety-critical applications, notwithstanding any applications-related information or support that may be provided by TI. Further, Buyers must fully indemnify TI and its representatives against any damages arising out of the use of TI products in such safety-critical applications.

TI products are neither designed nor intended for use in military/aerospace applications or environments unless the TI products are specifically designated by TI as military-grade or "enhanced plastic." Only products designated by TI as military-grade meet military specifications. Buyers acknowledge and agree that any such use of TI products which TI has not designated as military-grade is solely at the Buyer's risk, and that they are solely responsible for compliance with all legal and regulatory requirements in connection with such use.

TI products are neither designed nor intended for use in automotive applications or environments unless the specific TI products are designated by TI as compliant with ISO/TS 16949 requirements. Buyers acknowledge and agree that, if they use any non-designated products in automotive applications, TI will not be responsible for any failure to meet such requirements.

Following are URLs where you can obtain information on other Texas Instruments products and application solutions:

Products

Amplifiers	amplifier.ti.com
Data Converters	dataconverter.ti.com
DSP	dsp.ti.com
Clocks and Timers	www.ti.com/clocks
Interface	interface.ti.com
Logic	logic.ti.com
Power Mgmt	power.ti.com
Microcontrollers	microcontroller.ti.com
RFID	www.ti-rfid.com
RF/IF and ZigBee® Solutions	www.ti.com/lprf

Applications

Audio	www.ti.com/audio
Automotive	www.ti.com/automotive
Broadband	www.ti.com/broadband
Digital Control	www.ti.com/digitalcontrol
Medical	www.ti.com/medical
Military	www.ti.com/military
Optical Networking	www.ti.com/opticalnetwork
Security	www.ti.com/security
Telephony	www.ti.com/telephony
Video & Imaging	www.ti.com/video
Wireless	www.ti.com/wireless

Mailing Address: Texas Instruments, Post Office Box 655303, Dallas, Texas 75265
Copyright © 2008, Texas Instruments Incorporated